

PROTEUS NESTOR

TRAILED SPRAYER



carrarospray®

Proteus

TRAILED SPRAYER 1100-1600-2100 LT
WITH OCTAGONAL DIFFUSOR
FRONTAL SUCTION



- Polyethylene tank
- Jet agitation
- Frontal suction, self cleaning filter,
2 filters before nozzles
- Volumetric pump in anodized aluminium
- Double nozzles in brass with adjustable position
- Gearbox 2 speed and neutral
- Fan d. 800 Mm with clutch
- External premixer completed of washing tins



PESTICIDE TREATMENTS IN VINEYARDS AND ORCHARDS IN SLOPE AND IN FLAT,
ROWS 2-4,5 M, HIGH OF VEGETATION UP TO 5 M

Nestor

TRAILED SPRAYER 1100-1600-2100 LT
WITH AXIAL FAN REAR SUCTION



- Polyethylene tank
- Jet agitation
- Frontal suction, self cleaning filter, 2 filters before nozzles
- Volumetric pump in anodized aluminium
- Double nozzles in brass with adjustable position
- Gearbox 2 speed and neutral
- Fan d. 800 Mm with clutch



PESTICIDE TREATMENTS IN VINEYARDS AND ORCHARDS IN SLOPE AND IN FLAT,
ROWS 2-4,5 M, HIGH OF VEGETATION UP TO 5 M

	MAIN TANK	LENGTH	WIDTH	HIGH	WEIGHT
	l	mm	mm	mm	kg
PROTEUS 1100	1100	2500	1180	1280	555
PROTEUS 1600	1600	2720	1300	1400	865
PROTEUS 2100	2100	3000	1380	1420	895
NESTOR 1100	1100	2520	1180	1280	525
NESTOR 1600	1600	2740	1300	1400	835
NESTOR 2100	2100	3020	1380	1420	865

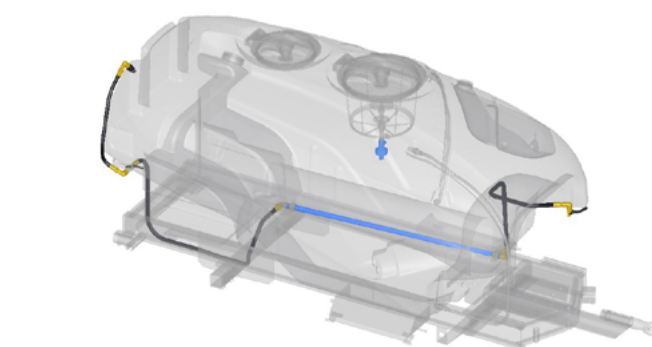
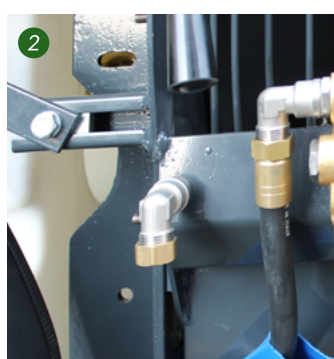

1. External mixer to treat the mixture in security
2. Simplify empty oil from pump and gearbox to assure max efficiency
3. Washing valve system
4. Control unit on left side
5. Jet agitation on length of tank to move in a constant way the mixture

